

Installation Manual

WINEGARD®
TRAV'LER®



Automatic
Multi-Satellite
TV Antenna

Model SK-SWM3
TRAV'LER® DIRECTV® SWM Slimline Antenna

www.winegard.com/mobile

For Technical Services, email help@winegard.com or call 1-800-788-4417

For Receivers and Programming, call 1-866-609-9374

For up-to-date information on receiver compatibility and programming,
visit www.winegard.com/receivers

Product Registration

Please register your Winegard product by filling out and returning the Product Registration Card provided or by completing the online registration form at <http://www.winegard.com/registration>.

Before Installing the Antenna

You have selected the Winegard® TRAV'LER® automatic multi-satellite TV antenna. The TRAV'LER antenna will deliver the ability to view multiple satellites at the same time with unmatched signal strength, the lowest travel height on the market, maximum HD capabilities and easy to use functionality—just like you get at home. This manual provides important information on the installation and operation of your TRAV'LER antenna on an RV. Please take time to read the manual in its entirety before installing or operating your antenna.

Follow the instructions on this side of the manual if installing the TRAV'LER DIRECTV SWM Slimline antenna. For operation instructions, follow the instructions on the reverse side of the manual.

Specifications

Depending on location and receiver type, the following satellites can be accessed with the TRAV'LER DIRECTV SWM Slimline antenna during automatic operation: 99°, 101°, 103°.

Height of assembled unit: 9.75"
Width of assembled unit: 34"
Length of assembled unit: 44"

Width of mount base: 21"
Length of mount base: 24"

Unit Weight: 53 pounds
Shipping Weight: 74 pounds

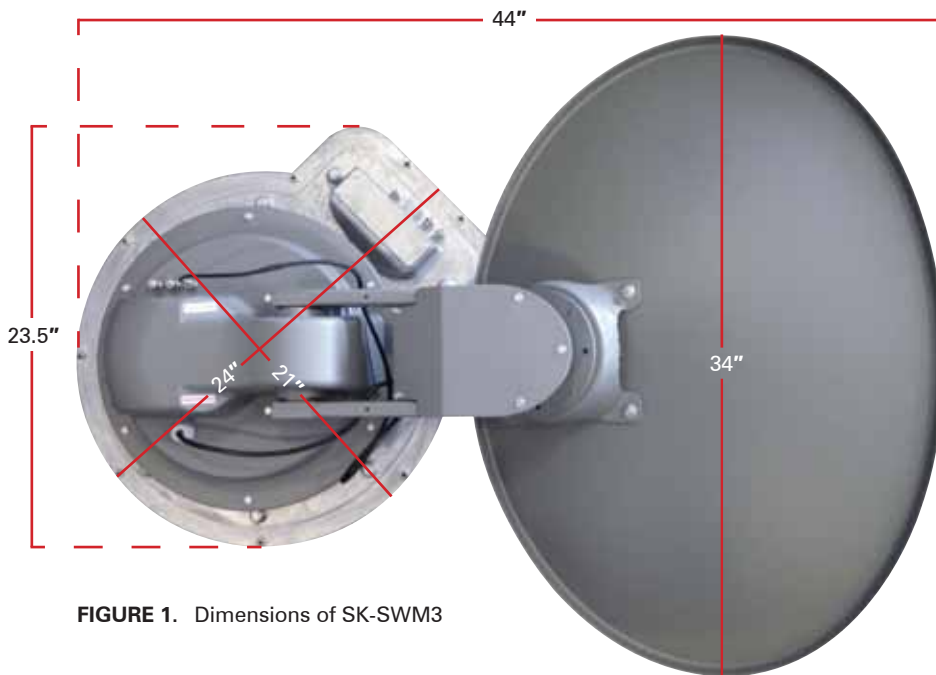

FIGURE 1. Dimensions of SK-SWM3

Safety Recommendations

Do not attempt to install this system in the rain or under any wet conditions. Moisture may affect electronics and void your warranty.

Do not paint this antenna. Painting the TRAV'LER antenna will void your warranty.

Pay attention to the pinch points as the antenna raises. The pinch points should be labeled on the antenna (see fig. 2).

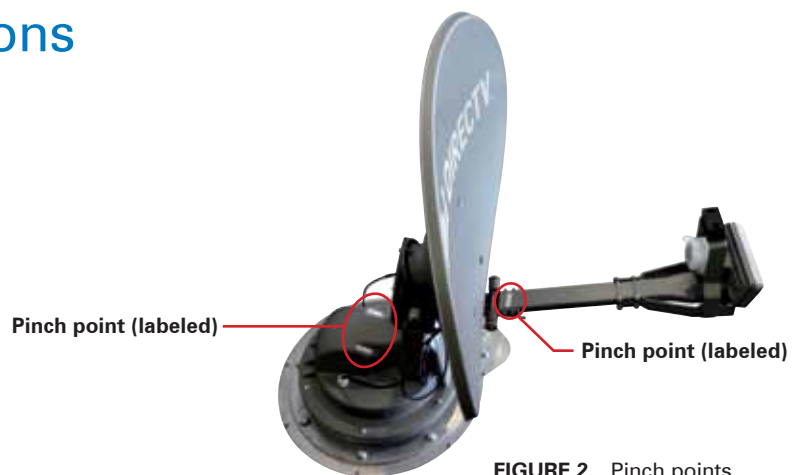

FIGURE 2. Pinch points

Clearance Requirements

The arm of the TRAV'LER antenna extends 33" from the center of the base and may operate only 10" above the surface to which the TRAV'LER antenna is mounted. **To ensure you have adequate clearance for the TRAV'LER antenna to safely operate, check that there are no obstructions taller than 10" within 33" of the center of the base.**

Also, check that there are no obstructions (such as tree limbs) above the antenna that will prevent it from raising. At its highest point, the antenna will extend to 37.5" above the roof to which it is mounted (see fig. 3).



FIGURE 3. Range of motion for TRAV'LER SWM antenna

Parts

Mount Base with 30' Power/Control Cable

21V SWM Power Inserter

Splitter

Interface Box Power Supply

Interface Box

Mounting Screw (20)

5/16" Reflector Nut (4)

5/16" Reflector Bolt (4)

24" AC power cord

30' Black Coax Cable

Cable Entry Plate

Reflector

Choosing a Location for the Antenna

1. For best performance and to reduce signal acquisition time, park the vehicle on a level surface that is free of obstructions such as trees or large buildings. Make sure you have a clear view of the southern sky.
2. Before removing the TRAV'LER antenna from its box, contact your RV dealer or manufacturer. Your RV may be pre-wired or have a reinforced area for this system.
3. Then, choose a location on the roof that meets the following requirements:

- a. Offers enough support for a secure installation
 - b. Allows dish to raise and rotate without interference from other roof-mounted equipment
 - c. Has a minimum roof space of 44" x 34" for antenna (see fig. 4)
 - d. Lacks obstructions taller than 10" mounted within a 33" radius from the center of the TRAV'LER base
 - e. Has a gap of less than 3/16" between the bottom of the antenna and the roof
- WARNING** Do not install the antenna in a location where a gap of 3/16" or more exists between the bottom of the antenna and the roof, as the antenna may damage the roof
- f. Is within 5 degrees of level, or the system may require more time to locate satellites (for best operation, must be within 3 degrees of level)

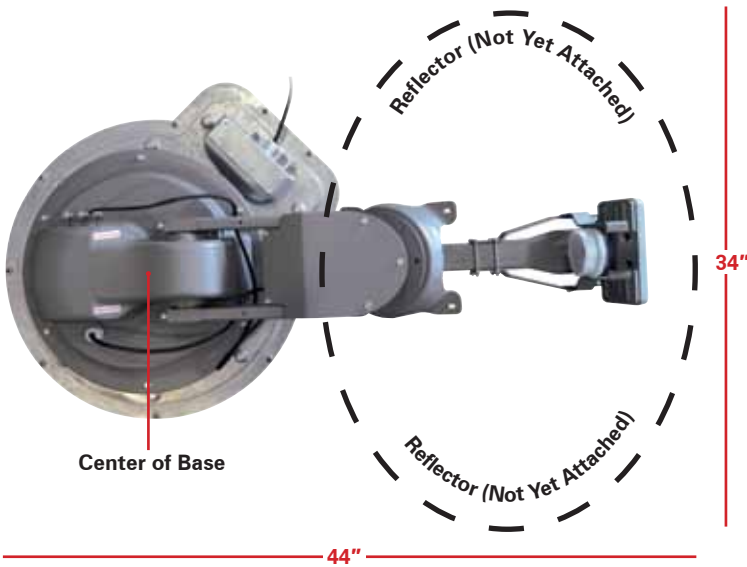

FIGURE 4. Required roof space for antenna

Choosing a Location for Cables to Enter the Vehicle

Once you have chosen a location for the TRAV'LER antenna, choose a location for the cables to enter the vehicle. Keep in mind the following:

1. The TRAV'LER interface box must plug into a well-ventilated 110 V outlet.
2. The 24" AC power cord must be long enough to extend from the outlet to the interface box power supply, which will then connect to the interface box.
3. The 30' control cable must be long enough to extend from the mount base to the interface box.
4. The power inserter must be mounted inside the vehicle, but the splitter can be mounted on the roof of the vehicle (see Setup Option 1 & Setup Option 2 under "Overall Setup").
5. Wires should not be run through the striped area (see fig. 5). Anything in the striped area will interfere with the operation of the TRAV'LER antenna and may cause damage to the object or to the antenna.

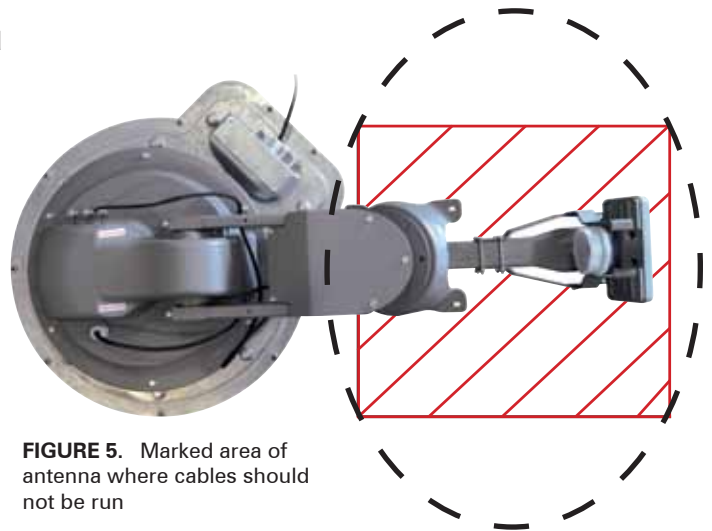

FIGURE 5. Marked area of antenna where cables should not be run

Make sure cables are long enough to reach their destination points inside the vehicle. For cable runs longer than 30', an extension may be purchased. Winegard recommends using Model CL-SK26 25' extension cable. Do not exceed 55' of cable!

WARNING Winegard is NOT liable for damage, expenses, or injury caused by improper installation.



Installing the Antenna

1. Place the TRAV'LER antenna on the roof where you plan to install it. On the mount base, the transition plate is marked "FRONT" and "BACK." Rotate the TRAV'LER antenna until the front of the mount base faces the front of the RV. **The TRAV'LER antenna must be installed on or parallel to the centerline of the coach.** See figure 6.

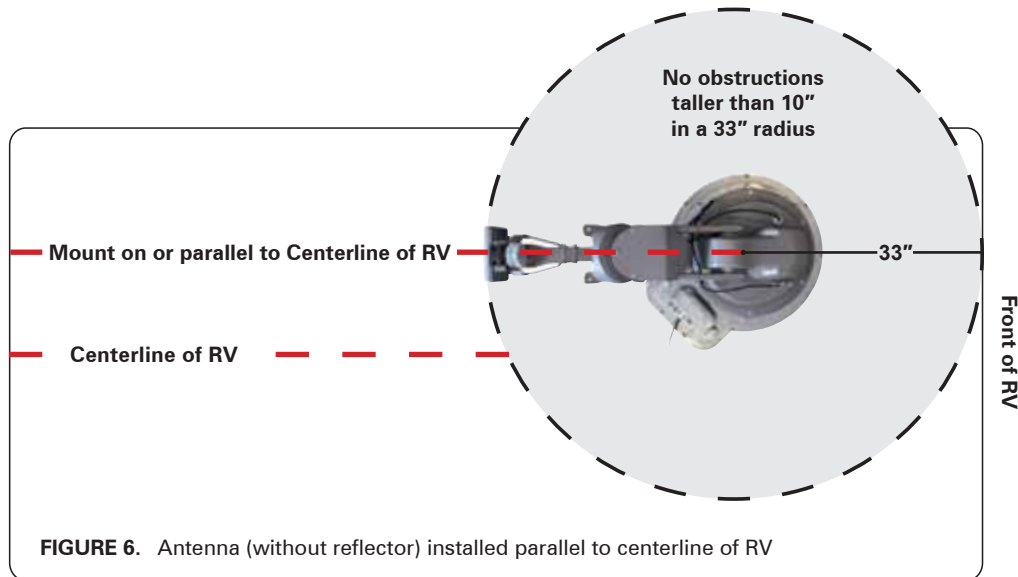

TIP When installing the antenna on a rubber roof, Winegard recommends using Model SKA-004 roller plate, which is designed to create a solid landing area for the roller. If not using this plate, make sure that the roller does not come in contact with any rib supports or bubbles in the roof when in operation. Failure to do so may result in damage to the roof.



2. Verify that the marked "FRONT" of the transition plate is facing the front of the vehicle (see fig. 7).



FIGURE 7. Marked "FRONT" of transition plate on fully assembled antenna

3. Mark the location where the nine screw holes will go. It is important that you can see these marks on the roof of the RV. Then, move the mount base out of the installation area. **It is recommended that you do not pre-drill the screw holes at this time.**
4. To prevent water from getting into the mount base, use a solid line of approved sealant to connect the marks in the shape of the base. This step *must* be completed, or the unit will fail due to corrosion. Replace the TRAV'LER antenna base.
5. Before using the supplied mounting screws, check with your vehicle manufacturer for any special screw requirements. Then, screw the antenna base to the roof using nine mounting screws.
6. Run a solid bead of sealant around the edge where the transition plate meets the roof, making sure to cover each screw head. Be careful not to get any sealant above the transition plate.

Overall Setup

Choose between Setup Option 1 and Setup Option 2 to connect all cables.

WARNING Only port C should be used for making connections to the mount base. Do not connect the power inserter or receivers to port A or B. Multiple receivers will connect to the mount base via the splitter.

In **Setup Option 1**, a cable runs from the TRAV'LER antenna to the power inserter and from the power inserter to the splitter; cables then run from the splitter to each receiver (see fig. 8).

WARNING The power inserter should not be mounted on the roof of the vehicle. The power inserter must always be installed inside the vehicle.

In **Setup Option 2**, a cable runs from the TRAV'LER antenna to the splitter and from the splitter to the power inserter and receiver(s) (see fig. 9).

TIP The splitter can be mounted on the roof of the vehicle. However, the power inserter must always be installed inside the vehicle.

Setup Option 1

1. Drill a 1" hole in the roof, and push the power/control cable and coax cable (running from port C of the mount base) through the hole. Place the supplied cable entry plate over the hole and cables, and screw the plate in place using eight of the supplied mounting screws. Seal the plate and screw holes with approved sealant (not included).
TIP Depending on the length of the cable on the roof, you may need to use cable clamps between the unit and the cable entry plate. Clamping every 12–16" should eliminate any unnecessary cable movement.
2. Connect the power/control cable running from the mount base to the "DC OUT/ANT. COMM." port of the interface box.
3. Connect the power supply to the "DC IN" port of the interface box.
4. Connect one end of the AC power cord to the power supply and the other end to a 110V outlet.
5. Connect a coax cable running from port "C" of the mount base to the "POWER TO SWM" port of the power inserter.
6. Connect a coax cable from the "SIGNAL TO IRD" port of the power inserter to the "In from SWM" port of the splitter.
Terminate unused splitter outputs with a 75 ohm termination cap.
7. Connect a coax cable from the splitter to each receiver. The receiver(s) should already be connected to the TV(s). Note that the provided coax cable only includes a connector on one end.
8. Plug in the power inserter to a 110V outlet.

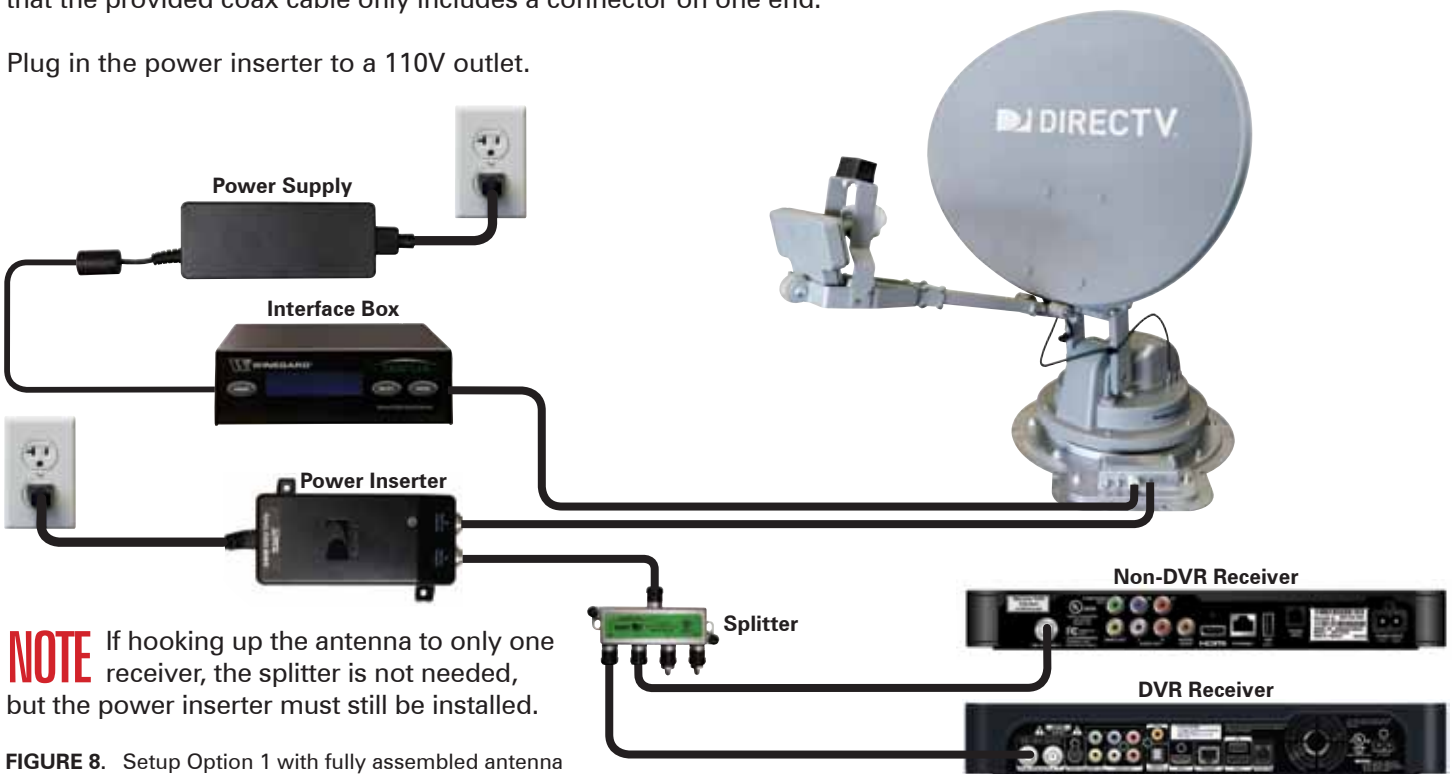

NOTE If hooking up the antenna to only one receiver, the splitter is not needed, but the power inserter must still be installed.

FIGURE 8. Setup Option 1 with fully assembled antenna

Setup Option 2

1. Drill a 1" hole in the roof, and push the power/control cable through the hole. If you would like any cables running from the splitter to enter the roof at this same point, push the cable(s) through this hole. Place the supplied cable entry plate over the hole and cables, and screw the plate in place using eight of the supplied mounting screws. If making multiple holes for cables to run from the splitter to each receiver, push the cables through the respective holes. Seal the plate, screw holes, and other drilled holes with approved sealant (not included).
TIP Depending on the length of the cable on the roof, you may need to use cable clamps between the unit and the cable entry plate. Clamping every 12–16" should eliminate any unnecessary cable movement.
2. Connect the power/control cable running from the mount base to the "DC OUT/ANT. COMM." port of the interface box.
3. Connect the power supply to the "DC IN" port of the interface box.
4. Connect one end of the AC power cord to the power supply and the other end to a 110V outlet.
5. Connect a coax cable from port "C" of the mount base to the "In from SWM" port of the splitter.
6. Connect a coax cable from the "POWER TO SWM" port of the power inserter to the "Out 1" port of the splitter, and connect the "SIGNAL TO IRD" port of the power inserter to a receiver. The "Out 1" port of the splitter is the only port that is power passive; therefore, the power inserter must be connected to this port of the splitter. **Terminate unused splitter outputs with a 75 ohm termination cap.**
7. Connect a coax cable from the splitter to each receiver. The receiver(s) should already be connected to the TV(s). Note that the provided coax cable only includes a connector on one end.
8. Plug in the power inserter to a 110V outlet.

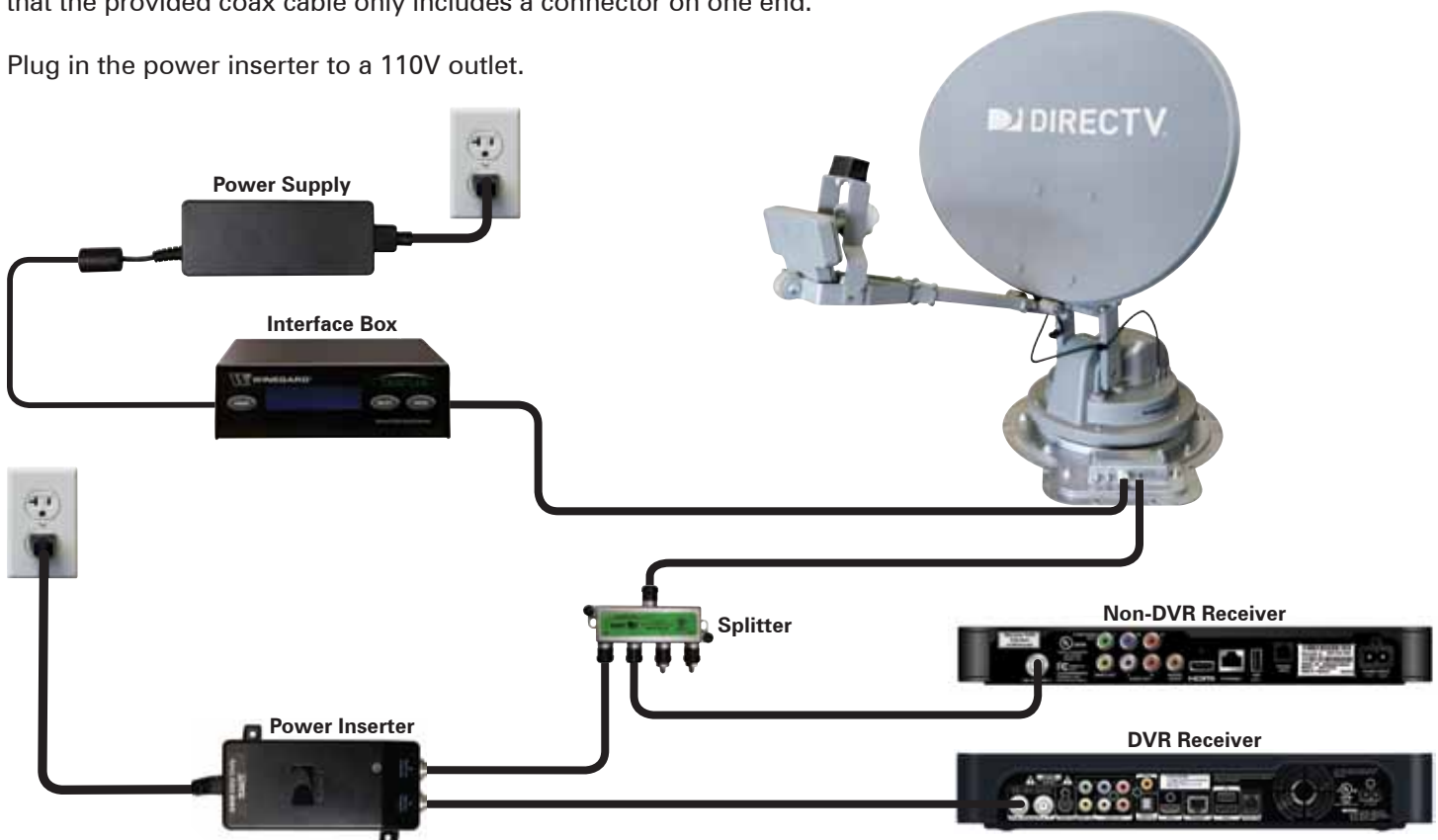

FIGURE 9. Setup Option 2 with fully assembled antenna

Installing the Reflector

Once the sealant around the cable entry plate has begun to cure, check that there is nothing above the unit that might prevent the antenna from raising. Follow the instructions on the next page to raise the antenna for reflector installation. In some cases you may be able to install the reflector with the unit in the stowed position; if so, skip to step 3.

Installing the Reflector, Cont.

1. Press "POWER," and hold for two seconds to turn on the interface box. Wait until the interface box finishes "connecting to antenna." The TRAV'LER antenna may enter the search routine after ten seconds. **Pay attention to the pinch points as the antenna raises.**
2. As the antenna raises, press "POWER" and "SELECT" at the same time. The antenna should stop moving.
3. Line up the four holes on the reflector with the four holes on the mounting bracket. Insert the four reflector bolts through the four holes on the front of the reflector. Thread a nut onto each bolt, and tighten the nuts.
4. Press and hold "POWER" for two seconds to power on the unit. Press "POWER" again until the interface displays "Stowing..."; this should lower the antenna to the stowed/travel position (see fig. 10).



FIGURE 10. Stowed/travel position

WINEGARD MOBILE PRODUCTS LIMITED WARRANTY (2 YEARS PARTS; 1 YEAR LABOR)

Winegard Company warrants this product against defects in materials or workmanship for a period of two (2) years from the date of original purchase. During year one (1) of such warranty, Winegard Company will also pay authorized labor costs to an authorized Winegard dealer to repair or replace defective products. No warranty claim will be honored unless at the time the claim is made, Customer presents proof of purchase to an authorized Winegard dealer (to locate the nearest authorized Winegard dealer, contact Winegard Company, 3000 Kirkwood Street, Burlington, Iowa 52601, Telephone 800-288-8094 or visit www.winegard.com). Customer must provide proof of purchase with a dated sales receipt for the Winegard product to verify the product is under warranty. If the date of purchase cannot be verified, the warranty period shall be considered to begin thirty (30) days after the date of manufacture.

If a defect in material or workmanship is discovered, Customer may take the product to an authorized Winegard dealer for service. Customer must provide proof of purchase to verify the product is under warranty. If the product is brought to an authorized Winegard dealer for service prior to expiration of year one (1) of the warranty period and a defect in material or workmanship is verified by Winegard Technical Services, Winegard Company will cover the Winegard dealer's labor charges for warranty service. The Winegard dealer must contact Winegard Technical Services in advance for pre-approval of the service. Approval of the service is at the sole discretion of Winegard Company.

Alternatively, Customer may ship the product prepaid to Winegard Technical Services (located at 3111 Kirkwood Street, Burlington, Iowa 52601, Telephone 800-788-4417). Customer must return the product along with a brief description of the problem and provide Winegard Technical Services with Customer's name, address, and phone number. Customer must also provide proof of purchase to verify the product is under warranty. If the product is returned before the expiration of the warranty period, Winegard Company will (at its option) either repair or replace the product.

This Limited Warranty does not apply if the product has been damaged, deteriorates, malfunctions or fails from: improper installation, misuse, abuse, neglect, accident, tampering, modification of the product as originally manufactured by Winegard in any manner whatsoever, removing or defacing any serial number, usage not in accordance with product instructions or acts of nature such as damage caused by wind, lightning, ice or corrosive environments such as salt spray and acid rain. This Limited Warranty also does not apply if the product becomes unable to perform its intended function in any way as a result of the television signal provider making any changes in technology or service.

RETURN AUTHORIZATION POLICY

A Return Material Authorization (RMA) is required prior to returning any product to Winegard Company or Winegard Warranty Services under this warranty policy. Please call our Technical Services Department at 800-788-4417 or send an e-mail to warranty@winegard.com to obtain the RMA number. Please furnish the date of purchase when requesting an RMA number. Enclose the product in a prepaid package and write the RMA number in large, clear letters on the outside of the package. To avoid confusion or misunderstanding, a shipment(s) without an RMA number(s) or an unauthorized return(s) will be refused and returned to Customer freight collect.

WINEGARD COMPANY DOES NOT ASSUME ANY LIABILITIES FOR ANY OTHER WARRANTIES, EXPRESS OR IMPLIED, MADE BY ANY OTHER PERSON.

ALL OTHER WARRANTIES WHETHER EXPRESS, IMPLIED OR STATUTORY INCLUDING WARRANTIES OF FITNESS FOR A PARTICULAR PURPOSE AND MERCHANTABILITY ARE LIMITED TO THE TWO YEAR PERIOD OF THIS WARRANTY.

In states that do not allow limitations on implied warranties, or the exclusion of limitation of incidental or consequential damages, the above limitations or exclusions do not apply.

Some states do not allow limitations on how long an implied warranty lasts, or the exclusion of limitation of incidental or consequential damages, so the above limitations or exclusions may not apply to you.

This warranty gives Customer specific legal rights. Customer may also have other rights that may vary from state to state.

SATELLITE RECEIVER WARRANTY
See manufacturer's limited warranty policy.

WS-MOBWARREV2
Rev. 1/10

Winegard Company • 3000 Kirkwood Street • Burlington, IA 52601 • 1-800-288-8094 • Fax 319-754-0787
www.winegard.com • Printed in U.S.A. ©2012 Winegard Company Rev3 2/14 2452282

Winegard and TRAV'LER are registered trademarks of Winegard Company. DIRECTV is a registered trademark of DIRECTV, LLC.

Disclaimer: Although every effort has been made to ensure that the information in this manual is correct and complete, no company shall be held liable for any errors or omissions in this manual. Information provided in this manual was accurate at time of printing. The satellite interface is designed specifically for use with motorized recreational vehicles, and information contained herein is provided for that purpose only.

Check the data cable connection on the back of the interface box. It may not be connected properly.

EL HOME FAILURE

Something is preventing the mount from raising as it attempted to find the HOME position. Look for obstructions if the unit has recently been manually raised or if the electronics have been replaced. The calibration may need to be reset. Contact Winegard Technical Support at help@winegard.com or 1-800-788-4417.

AZ MOTOR STALLED

Something is preventing the mount from rotating; look for obstructions. If there is no obvious obstruction, contact Winegard Technical Support at help@winegard.com or 1-800-788-4417.

EL MOTOR STALLED

Something is preventing the mount from raising or lowering; look for obstructions. If there is no obvious obstruction, contact Winegard Technical Support at help@winegard.com or 1-800-788-4417.

SK MOTOR STALLED

Something is preventing the reflector and LNBF from rotating; look for obstructions. If there is no obvious obstruction, contact Winegard Technical Support at help@winegard.com or 1-800-788-4417.

STOW FAILURE

The TRAV'LER antenna is not stowed. Do not try to move the vehicle. Try to stow the TRAV'LER antenna again. If it fails again, check for obstructions.

STOW FAILURE

Check the data cable connection on the back of the interface. It may not be connected properly.

AZ MOTOR RUN REVERSE

Contact Winegard Technical Support at help@winegard.com or 1-800-788-4417.

EL MOTOR RUN REVERSE

Contact Winegard Technical Support at help@winegard.com or 1-800-788-4417.

SK MOTOR RUN REVERSE

Contact Winegard Technical Support at help@winegard.com or 1-800-788-4417.

AZ MOTOR RUNAWAY

Contact Winegard Technical Support at help@winegard.com or 1-800-788-4417.

EL MOTOR RUNAWAY

Contact Winegard Technical Support at help@winegard.com or 1-800-788-4417.

SK MOTOR RUNAWAY

Contact Winegard Technical Support at help@winegard.com or 1-800-788-4417.

NO LNB VOLTAGE

The TRAV'LER antenna is not seeing the required 12-18 VDC needed to power the LNBF. Check the coax connections. If these are all connected properly, contact Winegard Technical Support at help@winegard.com or 1-800-788-4417.

UNKNOWN ERROR #####

Contact Winegard Technical Support at help@winegard.com or 1-800-788-4417.

C MOTOR NOT FOUND

Contact Winegard Technical Support at help@winegard.com or 1-800-788-4417.

ANTENNA WILL NOT
AUTOMATICALLY STOW

See emergency manual stow instructions on page 1 of the operation manual.

Weather and vehicle location can impact the ability of the TRAV'LER antenna to locate all of the required satellites. Obstructions such as buildings or tree limbs can block the satellite signals and prevent the TRAV'LER antenna from successfully locating all of the satellites during automatic operation. Make sure you have a clear view of the southern sky.

DIRECTV HD Receiver Setup

The following instructions assume that the TRAV'LER antenna has found and locked onto satellites 99°, 101°, and 103°. There should be an asterisk next to 99°, 101°, and 103° on the TRAV'LER interface.

In most receivers, the setup is done through the "Repeat Satellite Setup" option in your receiver menu. To access the "Repeat Satellite Setup" option, go through the following steps. The following instructions are based on an H24 receiver. If your receiver differs from the options shown below, you may need to consult your receiver manual.

Check out online receiver setup guides for your antenna at www.winegard.com/receivers/setupguide.php.



Press "Menu" on your remote. Under "Settings & Help," select "Settings."



Select "Satellite."



Select "Repeat Sat Setup."



If required, press the DASH (-) (underneath #7 on your remote).



Select "01: SWM" for the switch type. Set the dish type for "17: Slimline-3S (SWM)."



Select "Continue" to verify your setup.



Once your setup is verified, you may need to download a program guide. If so, press "Continue" when the status bar reaches 100%.



The receiver may run data feed and guide feed tests for a few moments. Then, you will be prompted to set up the remote. Select "Setup Remote" to do this at a later time.

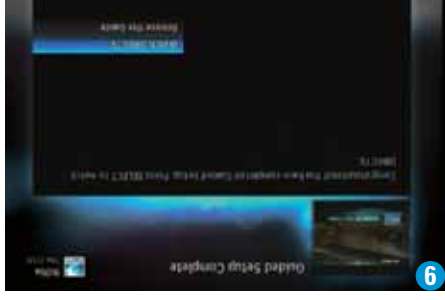

Select "Watch DIRECTV."

You are now ready to watch TV!

Operation

- The TRAV'LER antenna offers a simple one-button operation. Simply press "POWER," and the antenna will automatically begin searching for satellites. The instructions assume that the antenna is already in the stowed position.
1. Press and hold "POWER" for two seconds or until the TRAV'LER interface displays "POWER ON."
 2. Once the unit has been powered on, release "POWER."
 3. The interface screen will display the type of satellite dish on the top line.

LG DTV SWM3
Ready: Multi-Sat

5. In automatic search mode, the TRAV'LER antenna will lock onto three different satellites: 99°, 101°, and 103°. The antenna will display an asterisk for each satellite found.

LG DTV SWM3
*101 *99 *103

TIP If you want to turn off the power to the TRAV'LER antenna after the antenna has locked onto satellites, press "POWER" and "SELECT" at the same time.

Before traveling, make sure to press "POWER" and wait for the antenna to start to power up; then press "POWER" again to initiate the stow sequence. See below for information on stowing before traveling.

connecting to
antenna

5. The antenna will find its home position and begin to look for a satellite. Upon finding a satellite, the antenna will fine-tune or "peak" on the signal.

LG DTV SWM3
Home EL...

7. Continue to page 2 if setting up the receiver for the first time or if setting up the receiver after moving the receiver from the house to the RV. If the receiver is already set up in the RV, you are now ready to watch TV!

User Menu for Manual Operation

The interface includes a user menu for some advanced features. The options most commonly used are the ability to change the dish type, check software/hardware versions, change desired satellite configuration, or manually move the dish. Improper use of the user menu could cause damage to the TRAV'LER antenna and/or vehicle. Do not enter the user menu for regular operation.

Ready to Travel?

The TRAV'LER antenna is not meant for use while traveling. To stow the unit when you are ready to travel, press "POWER" one time. The unit will stop what it is doing and return to the stowed position. The TRAV'LER interface will not turn off unless the TRAV'LER antenna is successfully stowed. Visually inspect that the antenna is in the stowed/travel position before traveling. Do not move the vehicle until the TRAV'LER antenna is stowed.

Emergency Manual Stow

If unable to stow the TRAV'LER antenna, it may be necessary to use emergency manual stow. Emergency manual stow is meant as a last resort and is not meant for common usage! To use emergency manual stow, unplug the interface box. Then, remove the black plastic bolt from the back of the mount. Insert a 3/8th socket extension into this auxiliary drive. Turn the auxiliary drive clockwise to lower the unit. Do not use a drill!

Emergency Power Off

The antenna comes with an emergency power off feature. To activate it, press and hold "POWER" and then press "SELECT" while still holding "POWER". The TRAV'LER antenna will stop and turn off. If the emergency power off feature is used, the antenna may not be in a safe position for travel. Do not move the vehicle until the unit is stowed.

Operation Manual

Product Registration

Please register your Winegard product by filling out and returning the Product Registration Card provided or by completing the online registration form at <http://www.winegard.com/registration>.

visit www.winegard.com/receivers

For up-to-date information on receiver compatibility and programming,

For Receivers and Programming, call 1-866-609-9374

For Technical Services, email help@winegard.com or call 1-800-788-4417

www.winegard.com/mobile

Model SK-SWM3
TRAV'LER® DIRECTV® SWM Slimline Antenna

Automatic
Multi-Satellite
TV Antenna

